

Minimo[®]

ANGLON120 HEAD

H233

OPERATION MANUAL

MINITOR CO., LTD. JAPAN

21-1 Ryogoku 3-chome, Sumida-ku, Tokyo 130-0026 JAPAN
Phone +81 3 (6630) 5800 FAX +81 3 (6630) 5795

Products are subject to change without notice.

2024.11.01 IME-H233

MINITOR CO., LTD. JAPAN

Introduction

Thank you for purchasing Minimo ONE Series Ver. 3 Anglon120 Head.

Read this manual carefully for your safety prior to use.

Along with this manual, read manuals of Motor, Power Pack and foot switch, if used, carefully for your understanding of each function.

Keep this manual in place reach to easily.

Download this manual from our website if lost.

Precautions

- This manual indicates symbols and signal words intending to avoid dangerous operation and handling for potential hazards and accident that could result in personal injury or damage to the product.

Warning and Caution

Possible hazards and damages by wrong handling are classified as Warning and Caution in accordance with seriousness of risk.



Warning

Operation causing of significant and dangerous accident possibly resulting in death or serious injury.



Caution

Operation possibly causing of injury or physical damage on the product.

Warning

- **Do not press ON button on DC MOTOR selector and hand selector while collet chuck is in open.**
 - Motor may be overheated by energization in condition that motor is locked and may cause of fire and / or malfunction.
- **Confirm if handpiece works properly after turning DC MOTOR selector or hand selector on.**
 - May cause of fire and / or electric shock by overheating motor in case motor was not working.
Cause motor does not work: collet chuck in open, malfunction of handpiece, motor or power pack, etc.
- **Wear protective glasses for eye protection and respirator to prevent from dust.**
 - May cause of unexpected damage due to chip and dust.
- **In case abnormal noise, smoke and / or bad smell occurred, turn power switch off and unplug AC power cord.**
 - May cause of fire and / or electric shock.
- **Do not disassemble and / or remodel.**
 - May cause of fire, electric shock and / or malfunction.
 - May cause of significant influence on safety and performance.
- **Communication spark may occur while motor is rotating. Do not use the products near inflammable and explosive material such as thinner and gasoline.**
 - May cause of fire and / or malfunction.
- **Hold motor (handpiece) tight when turning switch on.**
 - May cause of injury and damage on tool by bouncing of motor (handpiece).
- **Do not touch rotating object such as Sentan Tool, collet chuck, etc. during operation.**
 - May cause of injury and damage on tool.

Caution

- **Do not use this product under environment generating corrosive gas . (chlorine gas, hydrogen sulfide, sulfuric acid gas, etc.)**
 - May cause of fire, electric shock and / or malfunction.
- **Use this product in condition without condensation.**
- **Use this product within temperature from 0°C to 40°C.**
- **Keep this product away from children.**
- **Do not drop and / or hit this product.**
- **Prevent dust, oil, water, etc. from entering inside. If liquid and / or foreign substances entered, turn power switch off, unplug AC power cord and ask us for repairing.**
- **Unplug AC power cord for your safety while replacing carbon brushes and other parts.**

1. Standard Accessories

- ◇ COLLET CHUCK ϕ 2.34 (KP-036) . . . 1pc.
- ◇ V-SPANNER (KP-609A) 1pc.
- ◇ JOINT SHAFT HOLD PLATE (KP-M01) . 1pc.
- ◇ SOFT RUBBER PAD ϕ 20 (SA2002) . . . 1pc.
- ◇ SOFT RUBBER PAD ϕ 30 (SA2003) . . . 1pc.
- ◇ SAND DISK #240 ϕ 21 (SA2135) . . . 5pc.
- ◇ SAND DISK #120 ϕ 31 (SA2153) . . . 5pc.
- ◇ FELT DISK ϕ 21 (SA3102) . . . 2pc.
- ◇ FELT DISK ϕ 31 (SA3103) . . . 2pc.

※The collet chuck ϕ 3.0 (KP-032) is mounted.

RATED SPEED : 15,000min⁻¹
RATED WHEEL DIAMETER : ϕ 30

Applicable Motors: KM213, KM213L,
KM113G, KX313

The accessories are subject to change without any notice.

2. Names

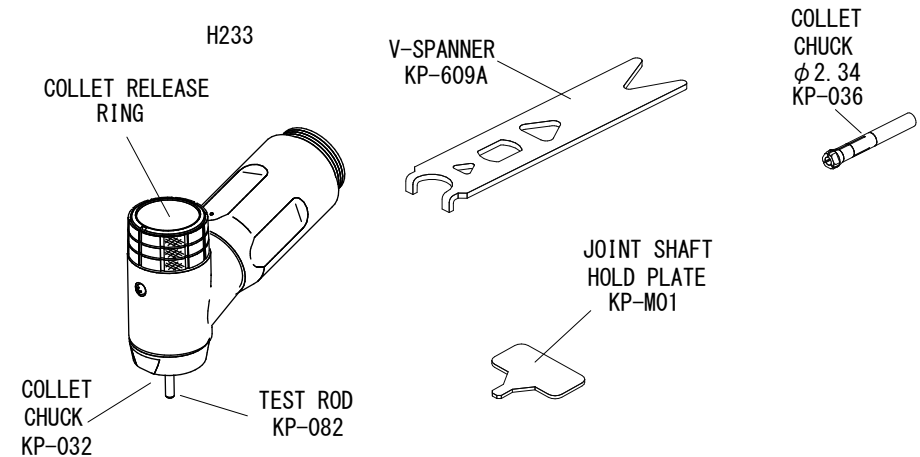

3. Operations

3-1. Attaching to the motor

- 1) Insert the H233 head onto the motor with placing the claw of the head in a groove of the motor.
- 2) Tighten the joint ring to secure the head in position.

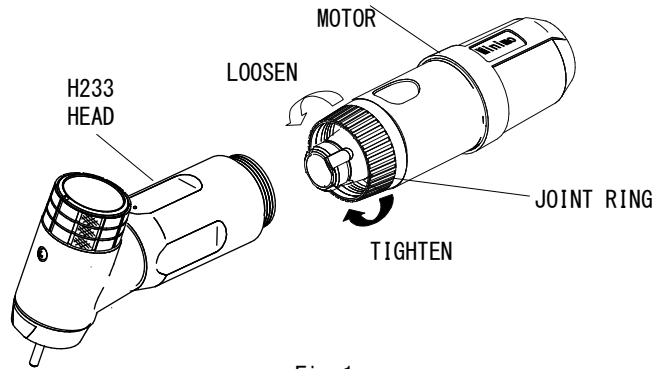

CAUTION ■ For your safety, do not connect the motor to the POWERPACK when attaching or detaching the head to the motor.

3-2. Changing the SENTAN tools

- 1) Hold the handpiece and turn the collet release ring until it locks in the right (RELEASE) position.
- 2) Pull out the test rod or SENTAN tool and insert the SENTAN tool suitable to the work.
- 3) Turn the ring till it locks in the left (SET) position.

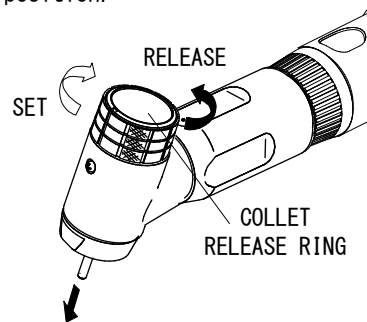

※The H233 head is shipped with a test rod to protect the collet chuck. Change it to the SENTAN tool suitable to the work.

◆The ring will be tight if you turn it to “S” position without any tools or test rod in the collet chuck.

CAUTION ■ Always keep the power OFF ON the POWERPACK when changing the tools.

3-3. Changing the collet chuck

- 1) Pull out the SENTAN tool as mentioned above.
- 2) Keep the collet release ring in right (RELEASE) position and insert the test rod into the collet chuck.
- 3) Use the small triangle hole on the V-SPANNER to hook the collet chuck and turn it to loosen.
- 4) Pull out the collet chuck and screw in the collet chuck suitable to the test rod into the collet and use the V-SPANNER to tighten it.

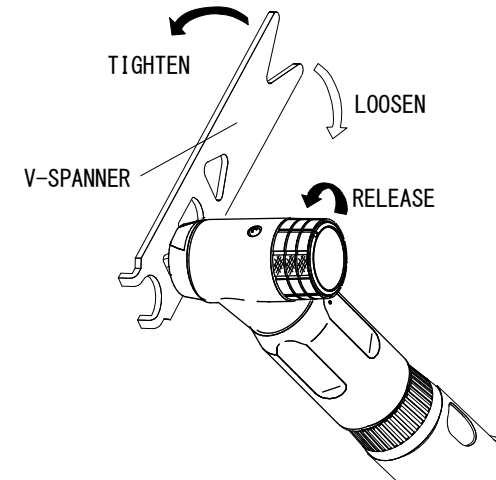

CAUTION ■ Always keep the power OFF when changing the tools.
■ Never turn the collet release lever when the motor rotating.
■ When tightening the collet chuck, always get test rod inserted into the collet chuck. Tightening the collet chuck without test rod will damage the collet chuck.

4. The Collet Chuck Options

H233 Applicable Collet Chucks

SHANK DIA.	φ 1.0	φ 1.2	φ 1.4	φ 1.6	φ 1.8	φ 2.0	φ 2.34	φ 3.0	φ 3.175
CODE NO.	KP-050	KP-051	KP-007	KP-005	KP-052	KP-031	KP-036	KP-032	KP-033

5. Maintenance

- The chips and dust may collect in the collet chuck.
Clean it by taking out the collet chuck from the handpiece.
- When the handpiece gets dirt, wipe out with cloth moistened with lukewarm water or detergent.

6. Important Notice

- Do not turn the collet release ring when the motor is running.
- No lubricant is needed.
- If used for wet grinding or polishing, water or oil may get into the main body and cause a malfunction.

7. Trouble Shooting

Trouble	Check	Remedy
Motor does not run.	Power switch of power pack is OFF.	Turn power switch of power pack ON.
	Carbon brushes are consumed.	Replace carbon brushes to specified ones.
	Collet chuck of handpiece is in open position.	Close collet chuck of handpiece.
Hand switch does not work.	Handpiece is controlled by external signal on power pack.	Control handpiece by external signal. Avoid controlling by external signal.
	Foot switch is connected.	Control by foot switch only.
Overheating while motor is running.	Dust, etc. are stuck on handpiece.	Remove dust, etc.
	Handpiece is used with excessive load.	Use motor within range of white LED indicating range of use on load meter.
High vibration and / or abnormal noise from handpiece.	Same malfunction is occurred in low rotation speed.	Ask for repairing.

If you still have a trouble after applying remedy, malfunction is considered. Ask for repairing.
If you have any question or need further assistance, please contact the store you purchased or us.